



## 105 MONO AMPLIFIER.

1. DESCRIPTION.
2. DISMANTLING.
3. DC AND POWER SUPPLY CHECKS.
4. AC CHECKS, FAULT FINDING AND SETTING UP.
5. CIRCUIT DIAGRAMS AND LAYOUT DIAGRAMS.
6. PARTS LIST.

1. DESCRIPTION.

The 105 is a high quality high fidelity self-powered mono power amplifier for use in musical applications.

The amplifier is built in two extrusions side by side, joined by long foot bars at the front and back. One extrusion houses the [unregulated] power supply and the other, the amplifier.

At the back of the power supply section there is a mains fuse, 3.15AT [slo blo], 20mm type. This value of fuse is common to all voltage versions of the 105. The fuse also feeds an IEC type mains outlet. Also at the back is a 6-pin chassis plug to feed the amplifier section. Most versions of the 105 have a LED indicator on the front, fed from the positive DC supply via limiting resistors.

At the back of the amplifier section there is a short cord with a 6-pin line socket. This line socket is plugged into the power supply section. There is a 3.15AF [quick blo], 20mm type fuse in series with the output to the loudspeaker. There are two 4mm output sockets for connecting a loudspeaker load to the amplifier. Suitable plugs are supplied plugged into these sockets. Input to the amplifier is provided via two Din sockets and also a parallel phono [RCA] socket. In some installations this phono socket is used for terminating the audio supply cable with a suitable load resistance [usually 75 ohms].

2.

## DISMANTLING:

Ensure that the unit is disconnected from the supply before dismantling.

To remove the POWER SUPPLY SECTION, unplug the amplifier section and unplug any ancillary equipment from the IEC mains socket.

Lay the unit upside down on a clean soft cloth.

Using a 1-pt pozi screwdriver, remove the four screws at the corner of the power supply tray.

Ease the back end of the power supply up, taking care to lay the mains cord against the back face so that it does not get damaged by the case. Once raised so that the works are clear of the back foot bar, the power supply may be eased backwards and then raised at the front also. There is a fairly short twisted wire feeding through the fire-guard in the case to the LED. Care must be taken not to tug this wire. The wire is long enough to allow the power supply tray to be laid with the works facing upwards [normal way up] beside the case.

To remove the AMPLIFIER SECTION, unplug the amplifier section from the power supply.

Place unit upside down on a clean soft cloth with the back towards you.

Undo the left hand slotted screw until it is almost free. Undo the right hand [shorter] slotted screw until it is fully undone.

By lifting the left hand screw, the front of the amplifier can be raised causing the right hand screw to protrude enough to allow it to be withdrawn. When the right hand screw has been removed, finish unscrewing the left hand screw and remove it.

Gently pull the amplifier out of the case backwards by the wire.

Keep the pasted spacer bar attached to the transistor plate clean. If necessary the PCB can be loosened from the bracket, and the insulating sheet removed, by undoing the two 6BA pozi screws near the back of the PCB.

NB When reassembling ensure that the spacer bar joined to the transistor plate has not picked up any foreign matter. If there is not sufficient paste on a clean spacer bar, the heat generated in the output transistors will not be speedily enough transferred to the heat plate and case. It is ESSENTIAL that attention be paid to this point.

Always reassemble using the long screw in the left hand hole first. Once the screw has been started in the thread, the amplifier can be lifted by the screw to enable the shorter screw to engage in its thread.

3.

## DC AND POWER SUPPLY CHECKS:

The power supply produces + and - 55 volts. It is not recommended that these voltages be checked at the 6-pin output plug. Accidental shorting of the pins with a meter probe will probably destroy the plug and probe due to the large charge in the smoothing capacitors. The voltages may be checked within the amplifier. Additional DC voltages appear at the points shown on the layout diagram.

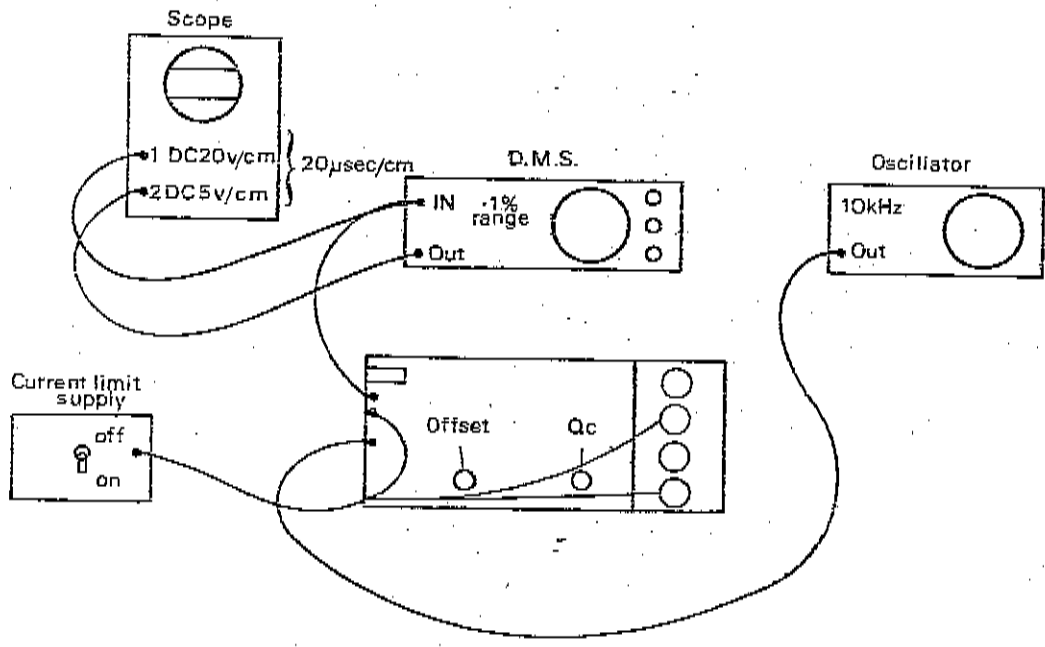

4.

## AC CHECKS, FAULT FINDING AND SETTING UP:

Maximum peak to peak output volts [ $<80$  volts] result from an input of 775mV RMS.

Once the existence of a fault within the amplifier circuit has been established by observing that the amplifier will not perform with the correct value unruptured fuses fitted or by observing that correct value fuses rupture when switched on, the following procedure should be adopted.

NB The minimum equipments required for correcting faults and setting up this power amplifier are as follows:

Low distortion oscillator [LDO].

Double beam oscilloscope.

Distortion measuring set [DMS].

Positive and negative current limited supply [see design for this in section 5].

A universal meter.

an 8-ohm resistive load of minimum 25 watt rating.

With no load connected to the amplifier, connect up as shown, ensuring that supply to the amplifier is ON LIMIT.

Turn RV2 fully clockwise. This ensures that the amplifier can be fault-found on the limited supply. Observe the oscilloscope. If the waveform is distorted, non-existent or seriously off-set [scope must be set to DC], a fault exists.

To assist in location of the faulty components, it is recommended that the input to the amplifier be grounded after the RC input filter at the junction of R5 and R6.

Since the amplifier is perfectly symmetrical, start by checking + and - power lines. A collapsed power line usually means that either an output transistor or pair is turned hard on by an earlier fault or an output transistor has collapsed. The failure of T9 or D11 will have a similar effect. Shorting C to E on T9 will check T9, and shorting D11 will check D11.

If the + and - 55 volt supply is OK, check the + and - 10 volt [zenered] supply to the early stages, [R8-R12 junction and R11-R15 junction. If neither + nor - 10 volt supply is present, suspect the thermal switch [mounted on the transistor heat plate]. The function of this switch is to short together the + and - 10 volt supply should the transistor plate reach 75°C.

It is possible to restore the 55 volt supply by removing with solder wick the solder round the base and emitter pins on the output transistors which may be pulling down the supply. Once the supply is restored, it is easier to look for an anomalous condition by comparing voltage drop across symmetrical pairs of resistors: e.g. R8 and R11, [1.1V]: R12 and R15, [0.5V]: R20 and R19, [0.6V]: R29 and R30, [0.6V]: R31 and R32, [0.6V].

Faults in the protection circuit can be checked by shorting R33 [checks T12 and D12] and R34 [checks T13 and D13].

After location and correction of a fault, remember to remove any short placed across the input [R5/R6 to ground]!

Once the amplifier is working, it is important to check that the protection circuits are OK. Driving a 10 kHz sine wave into 8 ohms, place a 3k3 resistor across first R35 and then R38. If the protection circuit is working, this action will clip each half of the waveform.

The DC offset of the amplifier can be adjusted to zero with RV1.

Check also that the Zobel network [R47 and C12] is OK. If R47 is burnt out, the amplifier will be extremely prone to further failure.

It is important not to use 'equivalent' semiconductors when repairing this amplifier. The performance, subjectively, of the amplifier may well be adversely affected by the use of 'equivalent' transistors, even if the measured performance appears to be within specification.

# 105

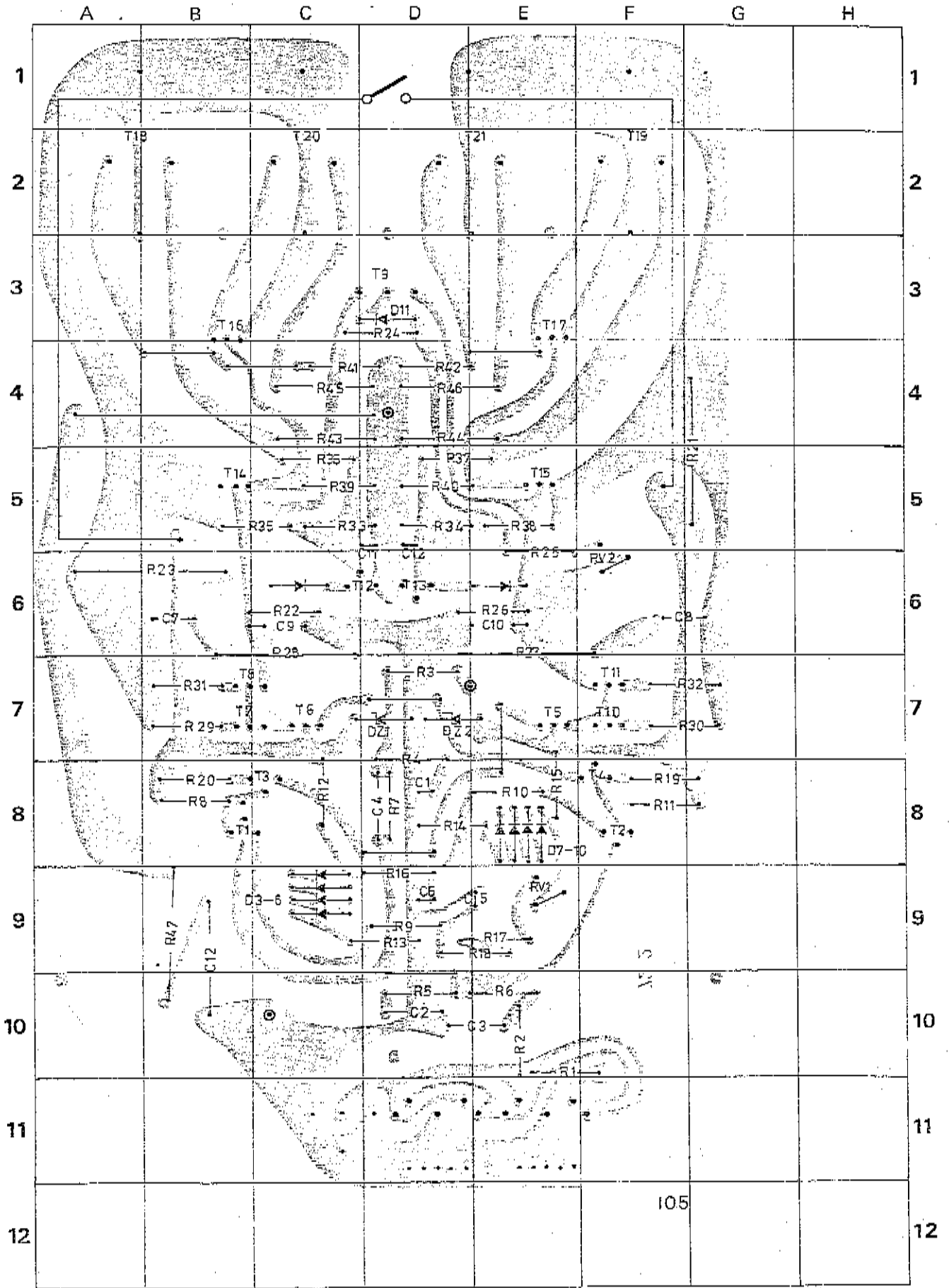

105

105

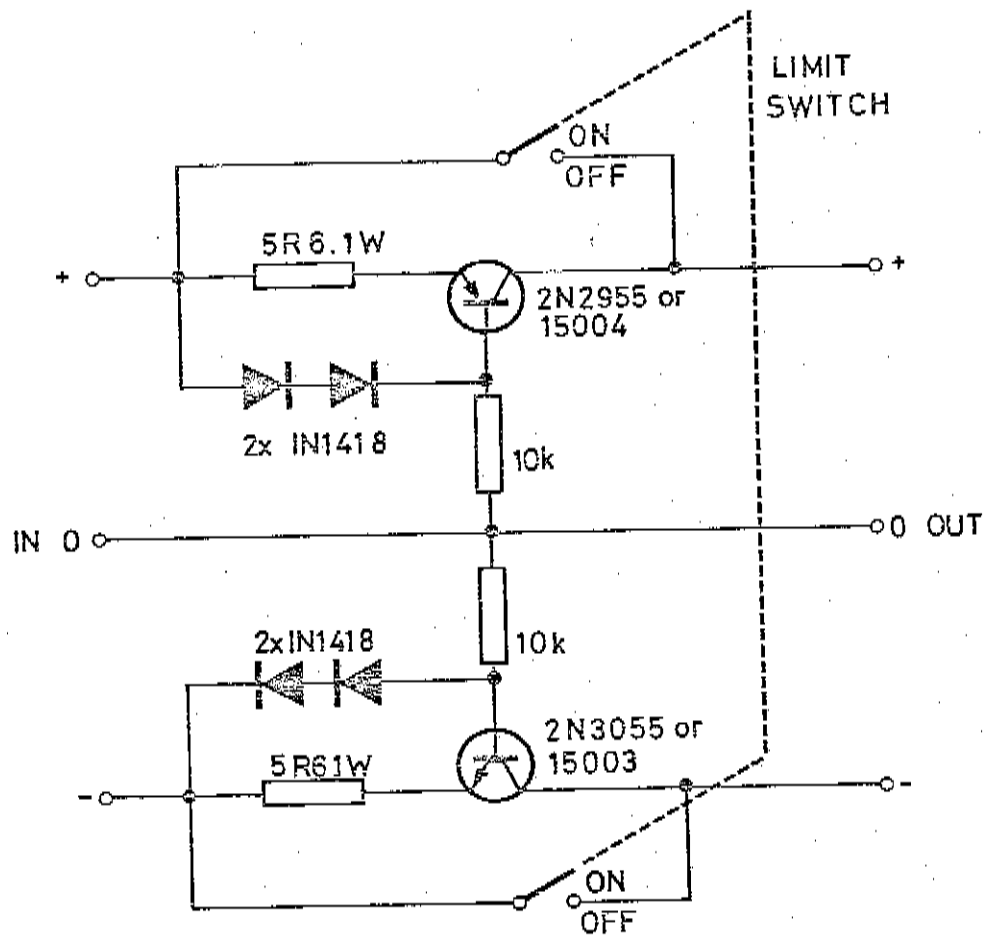

Supply circuit for servicing power amplifiers.  
Current limits at approx 100mA.

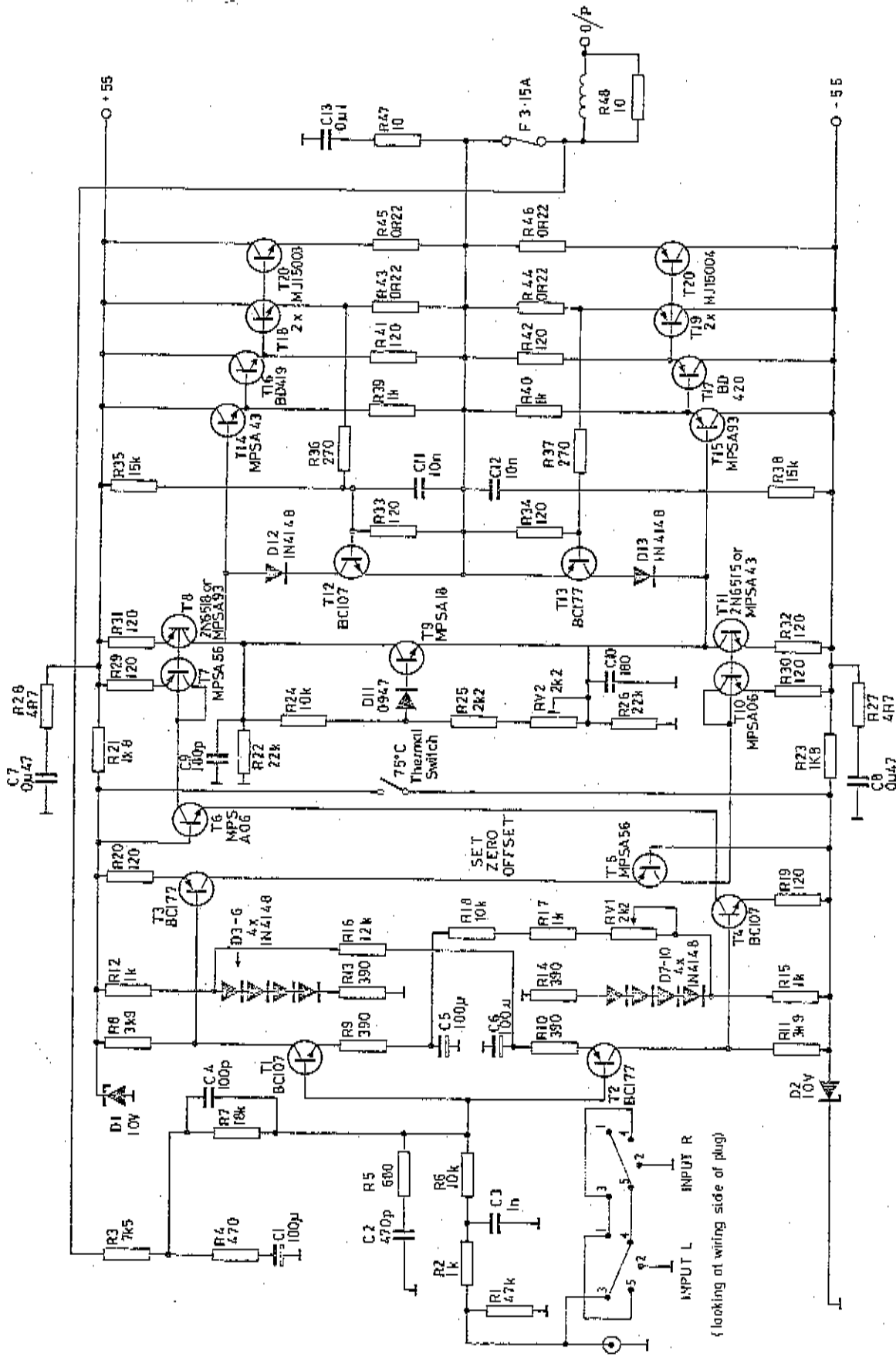
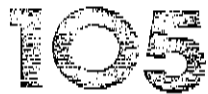

BOOTHROYD STUART MERIDIAN 105.



105 Power amplifier Parts List

POWER SUPPLY ASSEMBLY

1657P	1	Chassis	
1234	1	Transformer	* Fixes 1234
1230	1	Dished Washer with nut	Between 1234 and 1230
1230A	1	Sponge Washer	Fixes 1234
1713	1	Screw, 2BA 1 1/2" hex head	Between 1713 and 1657P
1739	1	Washer, 2BA 3/8" O/D plain	20 amp rating
1205	1	Bridge Rectifier	Retains 1205
1705	1	Screw, 6BA 5/8" c/s Pozl	For 1705
1708	1	Nut, 6BA Full	Between 1708 and 1705
1706	1	Solder tag, 6BA	Between 1706 and 170
1707	1	Washer, 6BA shake proof	* 1273 For Europe, 1273A for USA/Canada
1273	1	Mains Cord with IEC plug	For 1273 or 1273A
1232	1	Cable Retaining Bush	For 1232
1700A	1	Screw, 3/4" Self tap	* Mounted on rear panel
1272	1	IEC Mains Outlet Socket	1204 for Europe, 1204A for USA/Canada
1204	1	Fuseholder, 20 mm	Slo B10 for 1204/1204A
1201	1	Fuse 3.15AT Fuse, 20 mm	Power to amplifier
1220A	1	Plug, 6-pin chassis mounting	Between 1220A and 1657P
1260	1	O-Ring	
1138	2	Capacitor, 6800/63V	Current limiters for LBD
1064	2	Resistor, 2k7, 1/2W	Mounted in PSU section front panel
1255A	1	LBD, Yellow, 2 mm	USA/Canada only
1294	1	Fuseholder, Line, 1 1/4"	
1200C	1	Fuse 1.25AT, 1 1/4"	Slo B10 for 1294, USA/Canada only.

IMPORTANT: \* Indicates safety approved part. Use only direct replacement.

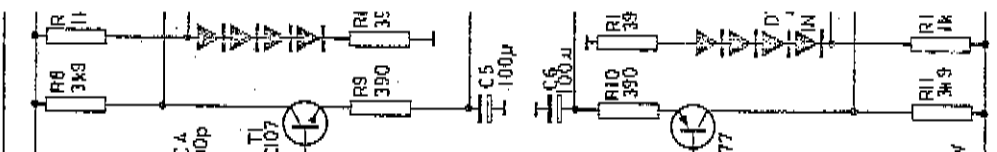

105 Power Amplifier Parts List.

CASE AND BRACKET ASSEMBLY.

Part No	Qty	Description	Remarks/Location
1463P	1	Case, Brown	Power Supply section
1466P	1	Case, Brown	Amplifier section
1464P	2	Long Foot Bar	Joining two case parts
1259	8	Rubber Foot	Retained in foot bars
1450S	1	Plain Front Screened	PSU section front
1450P	1	Plain Front	Amplifier section front
1486P	1	Small Filler Plate	Rear, PSU section underneath
1487P	3	Medium Filler Plate	Front, PSU and front & rear amp, underneath
1469A	1	Fireguard	Behind PSU section front panel
1478NP	1	Heatplate	Under amp section case
1806	1	Label	Back inside of 1466P
1807A	1	Label	Back inside of 1463P
1864	1	Insulating Square	Inside top of 1463P above transformer

Amplifier bracket assembly

1668P	1	Amplifier Bracket	Rear Panel, screwed to PCB
12080	1	Red Socket, 4 mm	Amplifier output socket
12090	1	Black Socket, 4 mm	Amplifier output socket
1232A	1	Cable Retaining Bush	Retains power lead from amplifier
1204A	1	Fuseholder	F396 type, in series with output
1201A	1	3.15AF Fuse, 20 mm	Quick blow [F] fitted to 1204A
1058AW	1	Output Choke/Resistor [R48]	Between fuseholder and 12080
1220AT	1	DC power lead with 6-pin 11ne socket	Connects to back of PSU section

